

Plasma Response to Oscillating Poloidal Current Drive in the Madison Symmetric Torus

A.P. Blair, K.J. McCollam, J.S. Sarff, J.R. Adney, J.K. Anderson, T.M. Biewer, D.J. Craig, W. Ding, G. Fiksel, T.W. Lovell, P.D. Nonn, S.C. Prager, J. Reardon, S. Terry

University of Wisconsin Madison

* This work supported by U.S. D.O.E.

ABSTRACT

A 1 MVA 500 Hz oscillator has been installed in the toroidal magnetic field circuit of the Madison Symmetric Torus (MST) Reversed Field Pinch. This device drives an alternating poloidal current in the edge of the plasma affecting the current profile and thus both the spectrum of the tearing mode fluctuations and energy confinement. We find that the amplitude of the dominant ($m=1$) modes rises and falls with the oscillating edge current while the $m=0$ mode amplitude appears to just the opposite. Simultaneous with the decreasing $m=1$ amplitude is a rise of the electron temperature in the core. These effects and an entrainment of the sawtooth instabilities with the applied oscillation are shown. This oscillator will operate with a similar device installed in the poloidal magnetic field circuit to test Oscillating Field Current Drive (OFCD). Initial OFCD results may be reported.

OUTLINE

- Ignitron based medium power oscillator design for OFCD
 - Designed, built, & tested Bt oscillator with MST.
 - Bp oscillator built and tested outside MST. Installing now.
 - Inexpensive solution for mid-power applications.
 - 700 kW peak/30 kW avg power achieved with prototypes.
- Experimental Data (with Bt oscillator only) shows:
 - Power delivered to plasma.
 - Sawtooth instabilities are entrained to applied oscillation.
 - Sawtooth growth is greatly accelerated and frequency is fairly well controlled.
 - Core-resonant $m=1$ mode amplitude responds to flux injection/anti-injection phase of oscillation.
 - Edge-resonant $m=0$ mode amplitude responds inversely so.
 - Ion temperature responds in phase with flux injection.
 - Fluctuation is large
- Preliminary OFCD results with both oscillators.
 - Indications of current drive.

Oscillating Field Current Drive

What is it:

A method of generating a sustained plasma current by applying two sinusoidal voltages 90° out of phase to the poloidal and toroidal circuits.

Rectification of oscillating currents is byproduct of conservation of global magnetic helicity.

Frequency for MST plasmas 100–1000 Hz.

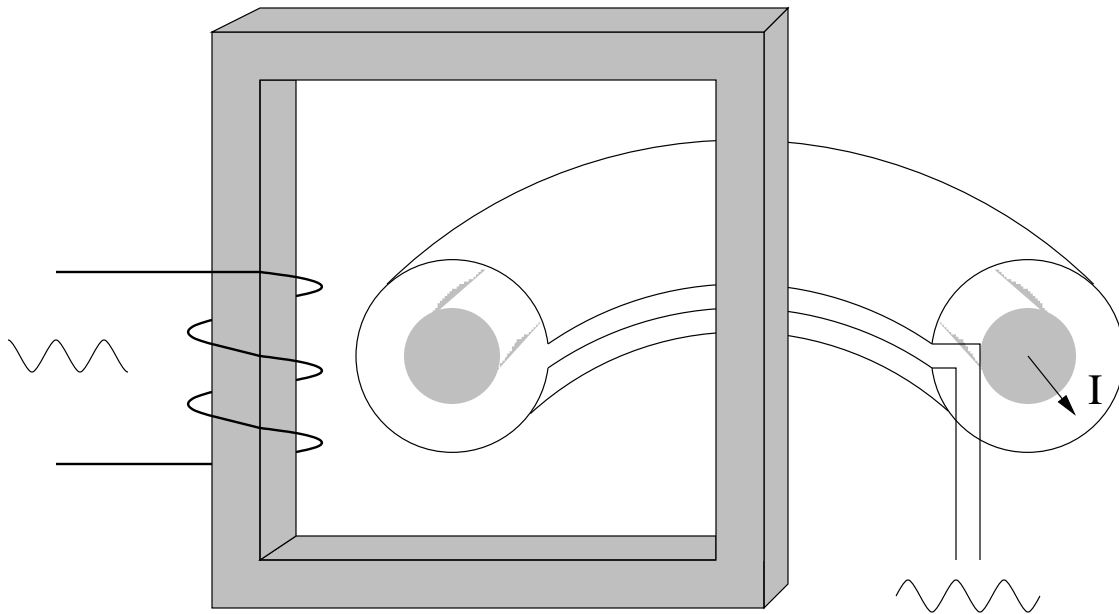

Hybrid Oscillator/Amplifier

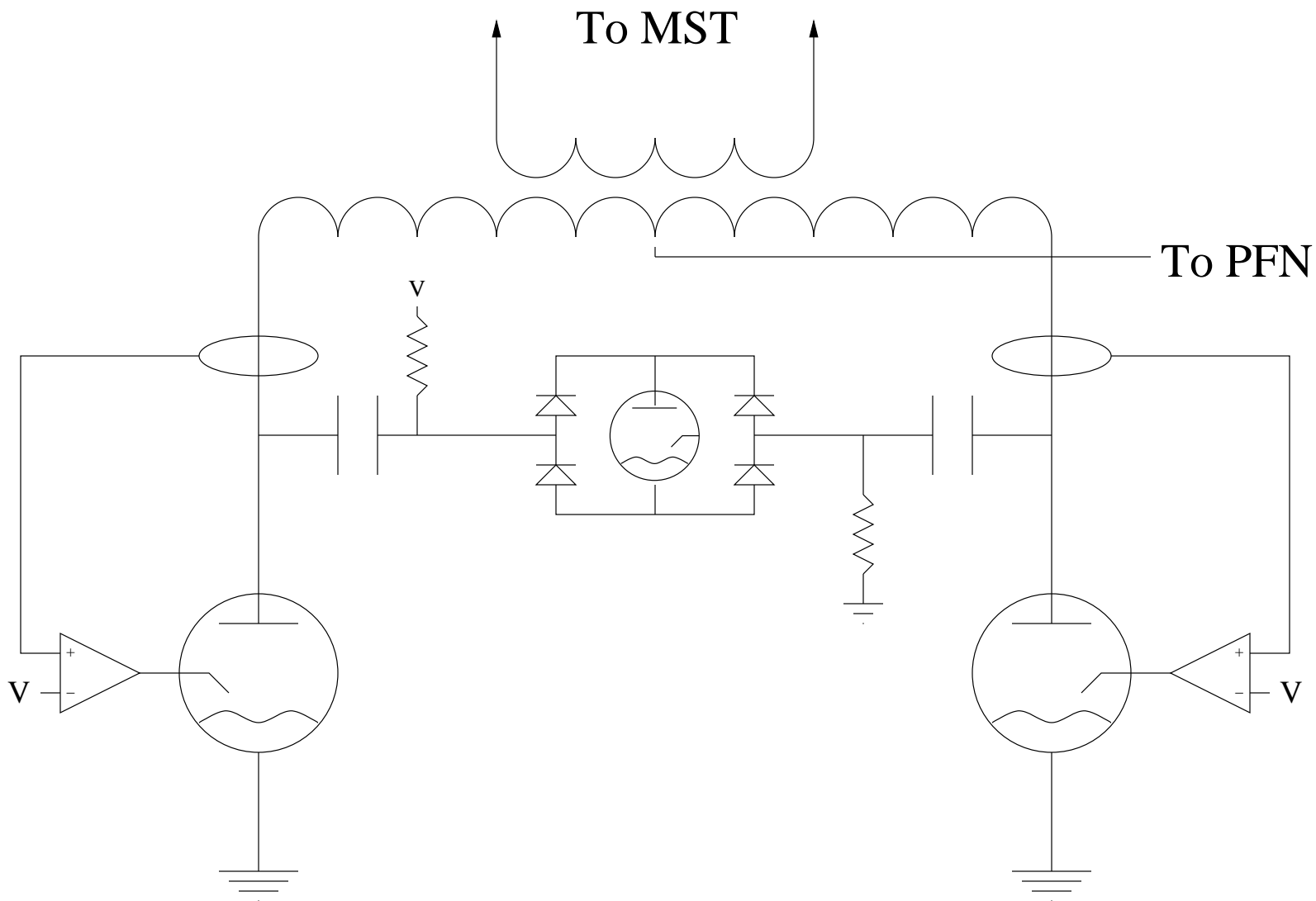

THE EXPERIMENTS

- Goal was to generate/study Bt oscillation with plasma.
- Diagnostics employed include:
 - Edge Magnetic probes (arrayed in toroidal & poloidal direction) :
 $B_{t_{\text{wall}}}$, I_{plasma} , V_{loop} , $V_{\text{toroidal gap}}$, etc.
 - Thompson Scattering : Electron Temperature
 - FIR interferometry/polarimetry : Density, B
 - Rutherford Scattering : Ion Temperature
 - Motional Stark Effect : Bt on axis
- Circuit variations have included:
 - Full wave rectifier in tank precharge circuit
 - + allows single ignitron to be used
 - Feedback of tank current to synchronize commutation instead of anode voltages.
 - + provides much cleaner/robust signals to feedback circuits.
 - Numerous simplifications.
- Preliminary OFCD experiments conducted recently.

Bt OSCILLATION

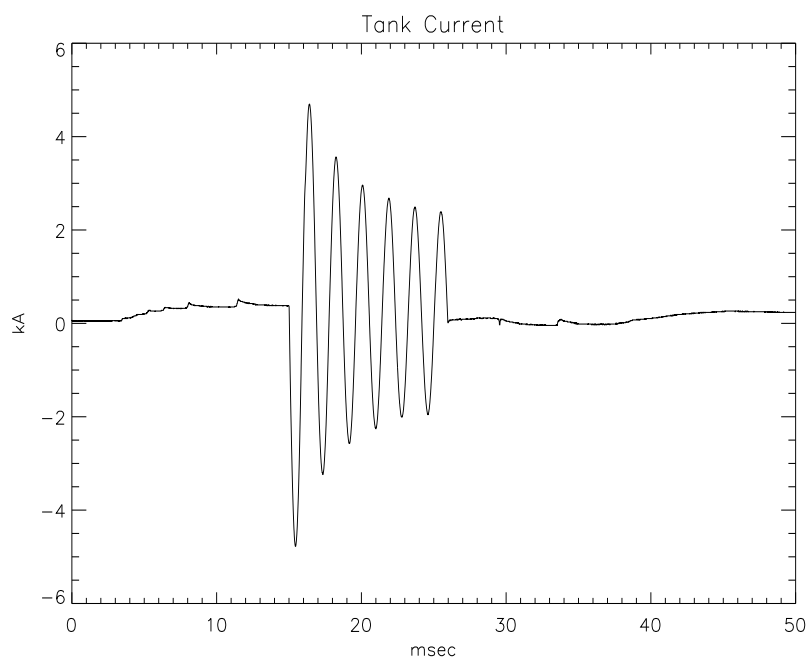

Oscillator output

- Shows a well defined pulse. Maximum power achieved on first cycle.
- Pulse width = 6 cycles

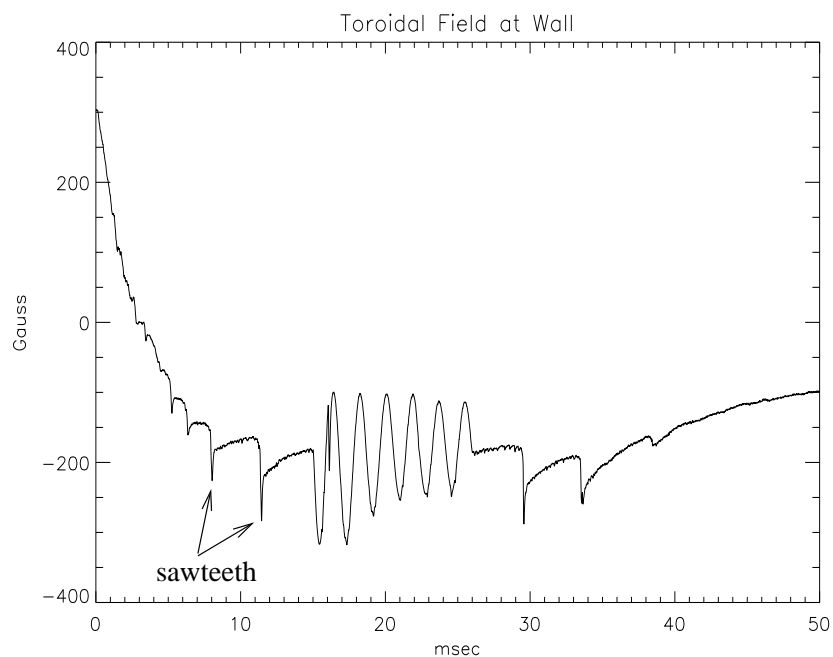

Toroidal Field Perturbation

- Oscillation is evident on B_{toroidal} measured at the wall.
- Oscillator is triggered after reversal has occurred.
- Oscillation is significant perturbation compared to sawteeth.

POWER & RESISTIVE LOADING

Voltage and Current

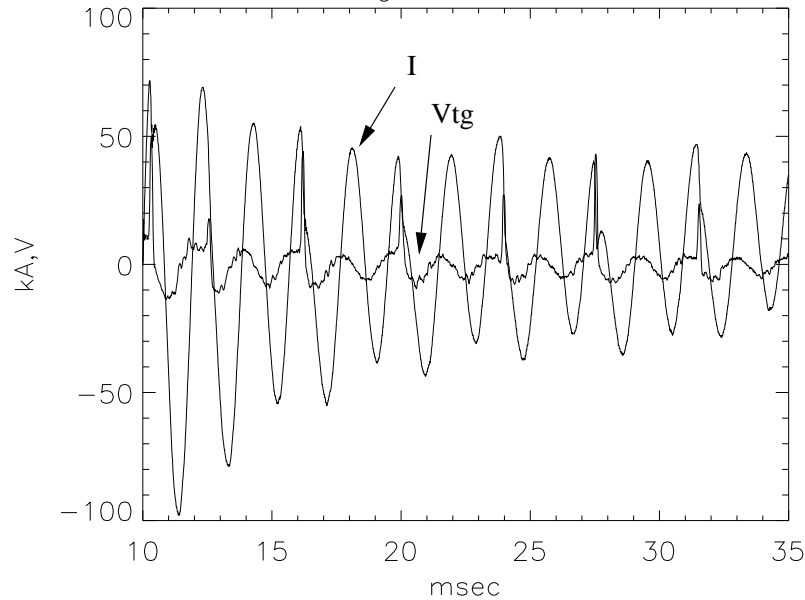

I and V

- Shows magnet current and voltage measured at toroidal gap
- Noise in V measurement due primarily to sawteeth instabilities.

Instantaneous Power

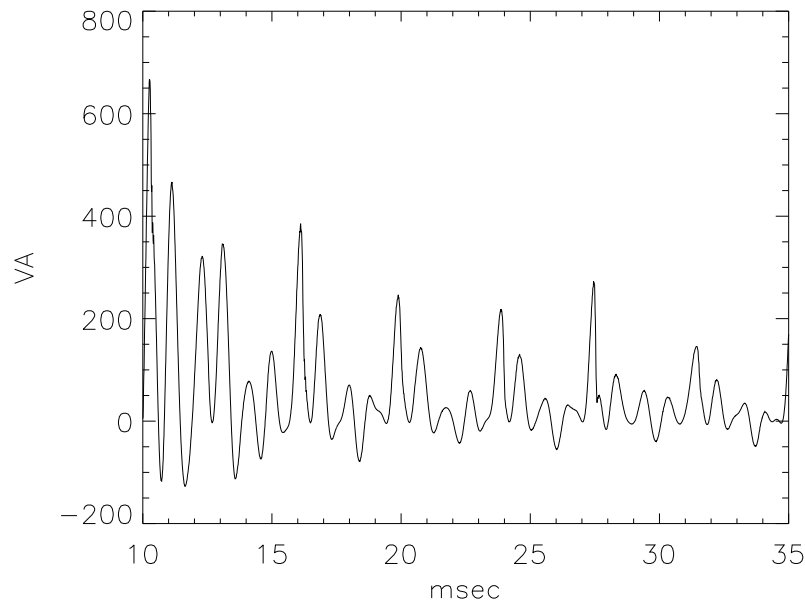

Instantaneous Power

- Shows instantaneous power delivered to plasma.
- Average power = 30 kW
- Peak power = 700 kW

Reversal & Pinch Parameter

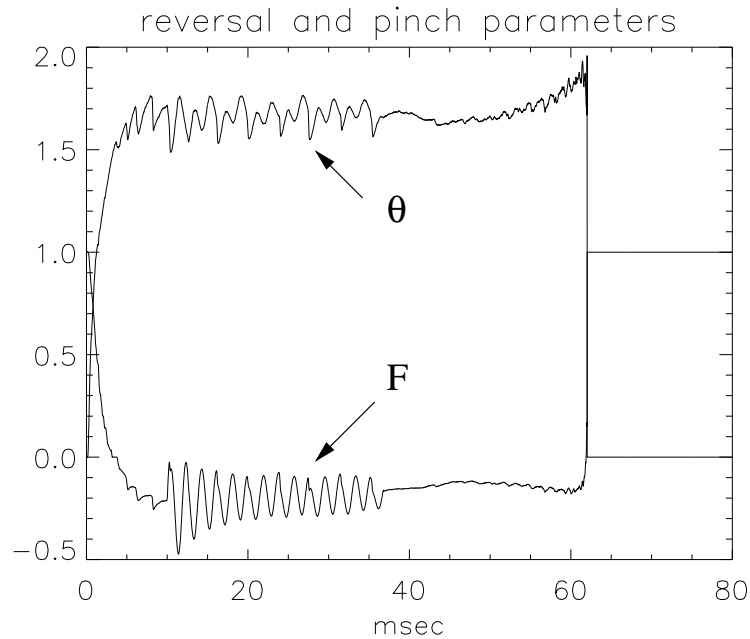

- $F = \text{reversal parameter}$

$$= \frac{B_{\text{toroidal at wall}}}{\langle B_{\text{toroidal}} \rangle}$$

- $\theta = \text{pinch parameter}$

$$= \frac{B_{\text{poloidal at wall}}}{\langle B_{\text{toroidal}} \rangle}$$

Three cycles of F vs θ

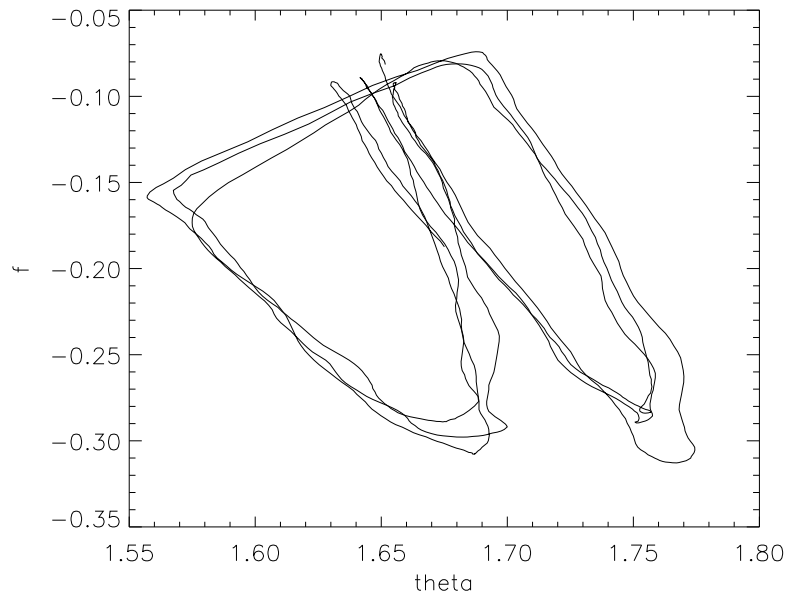

- Two lobes due to sawtooth entrainment
- Trajectory suggests plasma is not relaxed during oscillation cycle.
 - Perhaps lower frequency required

Reversal & Pinch Parameter

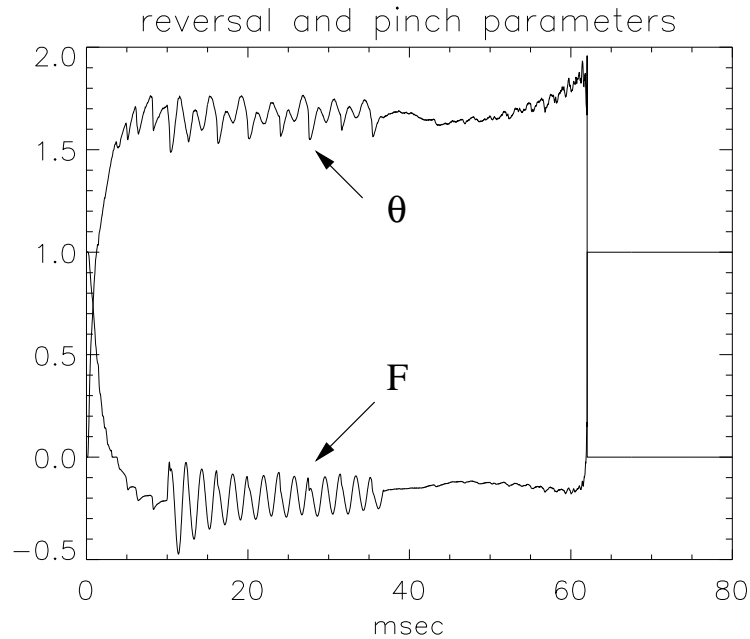

- $F = \text{reversal parameter}$

$$= \frac{B_{\text{toroidal at wall}}}{\langle B_{\text{toroidal}} \rangle}$$

- $\theta = \text{pinch parameter}$

$$= \frac{B_{\text{poloidal at wall}}}{\langle B_{\text{toroidal}} \rangle}$$

Three cycles of F vs θ

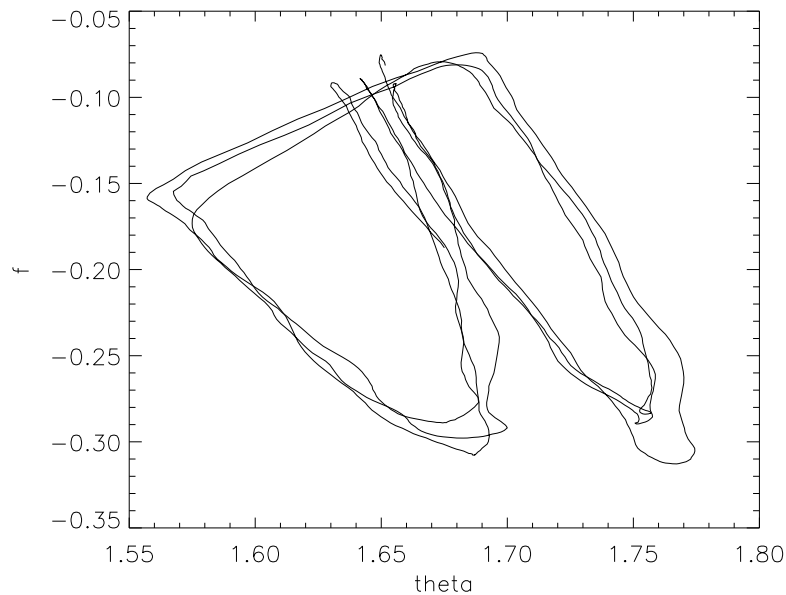

- Two lobes due to sawtooth entrainment
- Trajectory suggests plasma is not relaxed during oscillation cycle.
 - Perhaps lower frequency required

SAWTOOTH ENTRAINMENT

Toroidal Gap Voltage

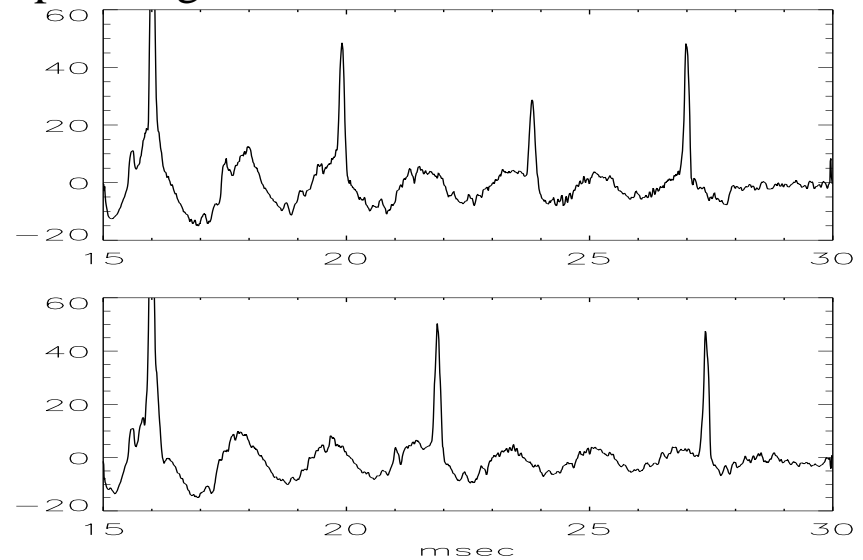
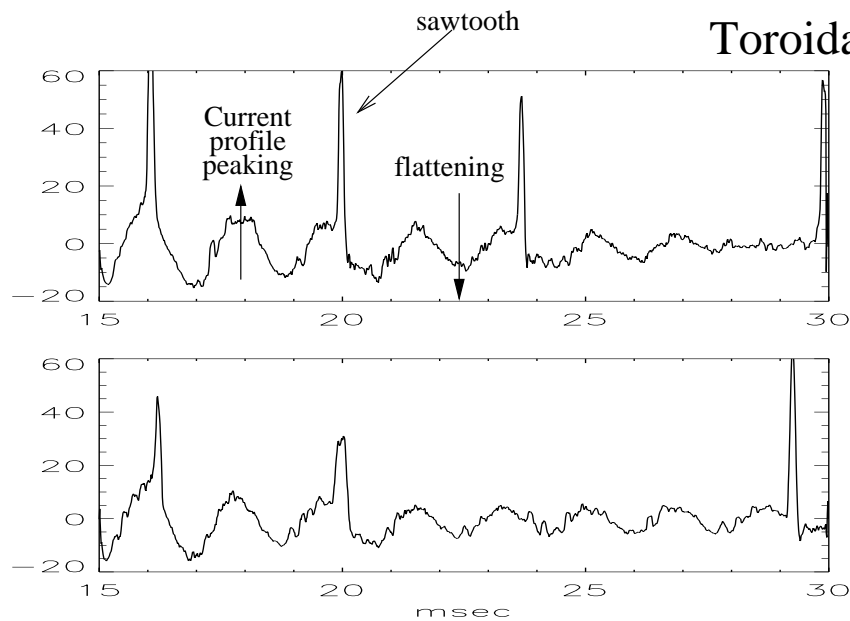

For Comparison: VTG without oscillator

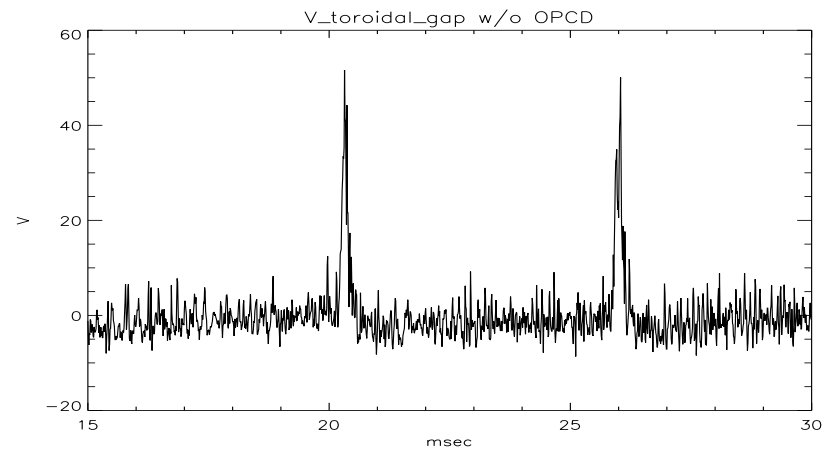
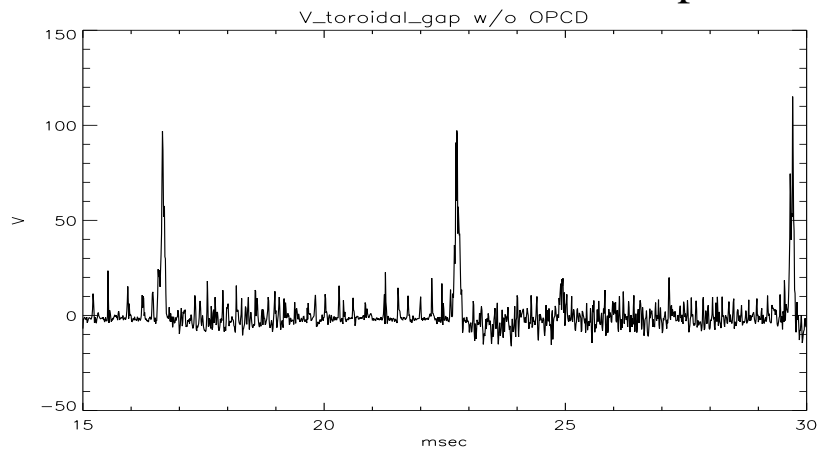

- Exact time of sawteeth varies but they always occur at peak of flux injection from OPCD.
- It appears plasma is trying to maintain normal sawtooth period subject to the phase of oscillator.

TOROIDAL FIELD ON AXIS

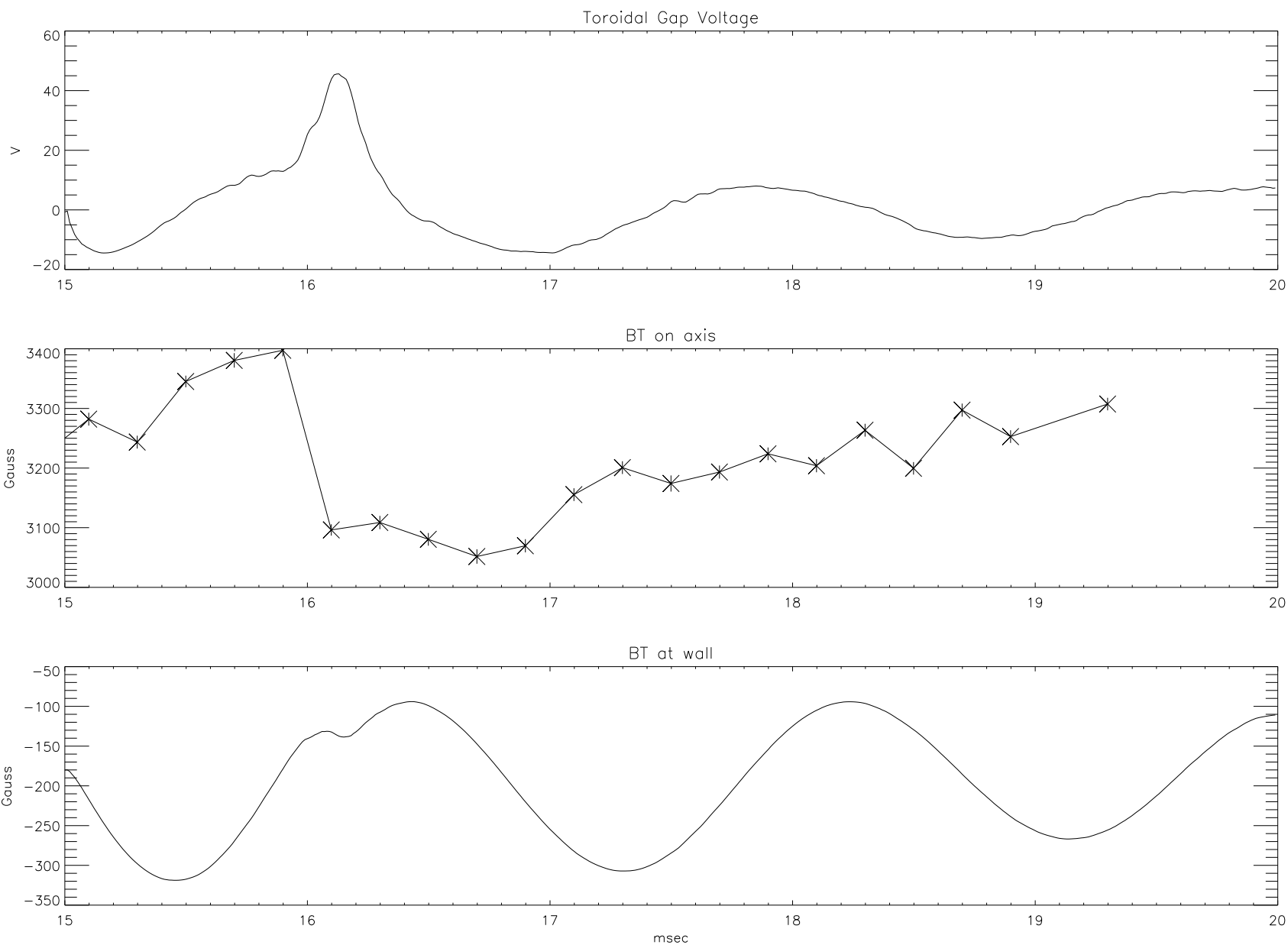

- Measured with Motional Stark Effect diagnostic
- No discernible oscillation in Toroidal Field on axis

MODE SPECTRUM WITH OSCILLATOR

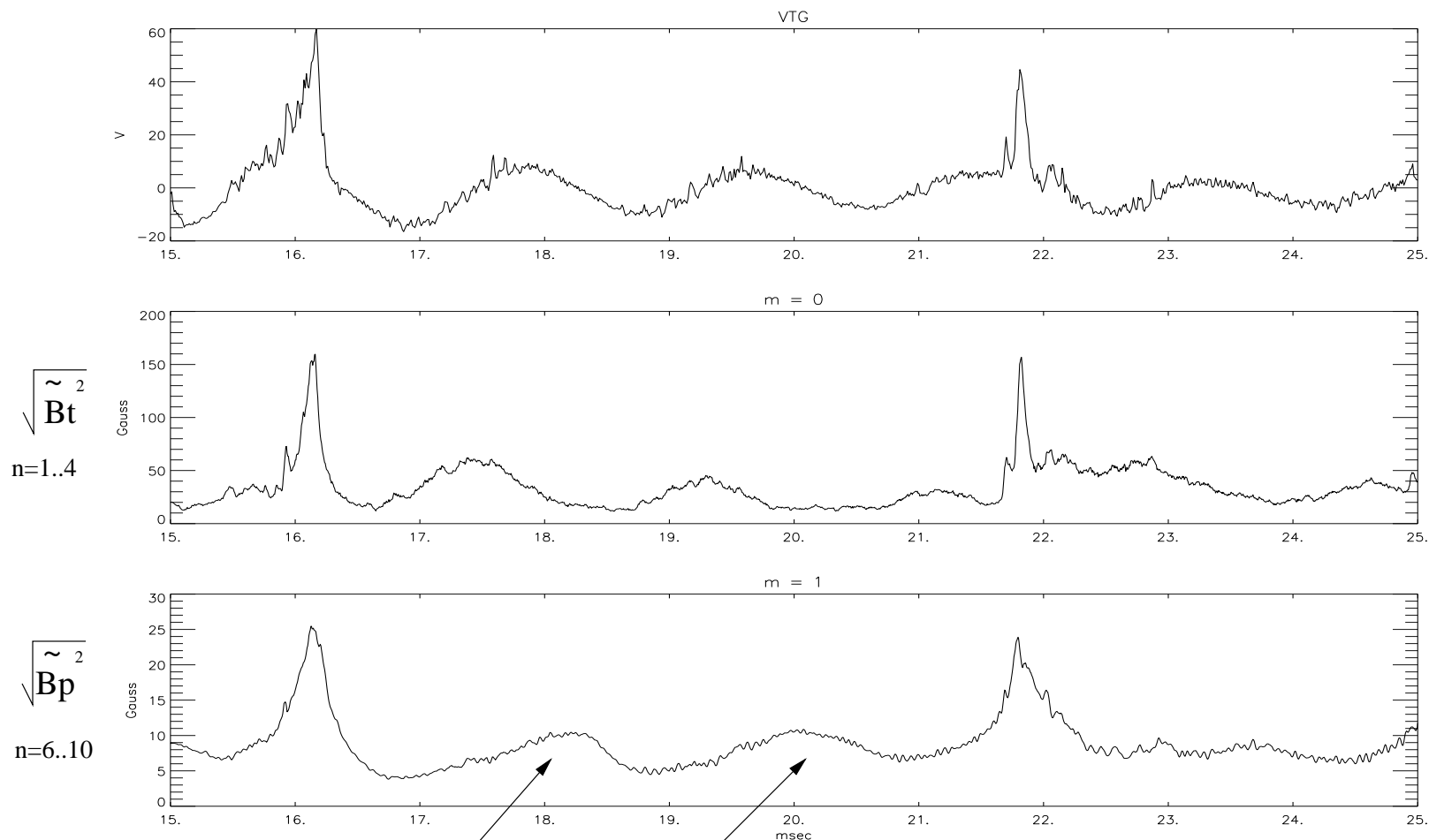

- The increase in m=1 amplitude between sawteeth does not occur in m=0 amplitude. In fact, m=0 amplitude appears to decrease when m=1 amplitude increases
- Typical 380 kA shot. density = 10^{17} per cc
- This effect and entrainment are more pronounced at lower plasma currents
- m=0 average = 30 G m=1 average = 10 G

OPCD ACCELERATES CORE MODE GROWTH RATES

Without
Oscillator

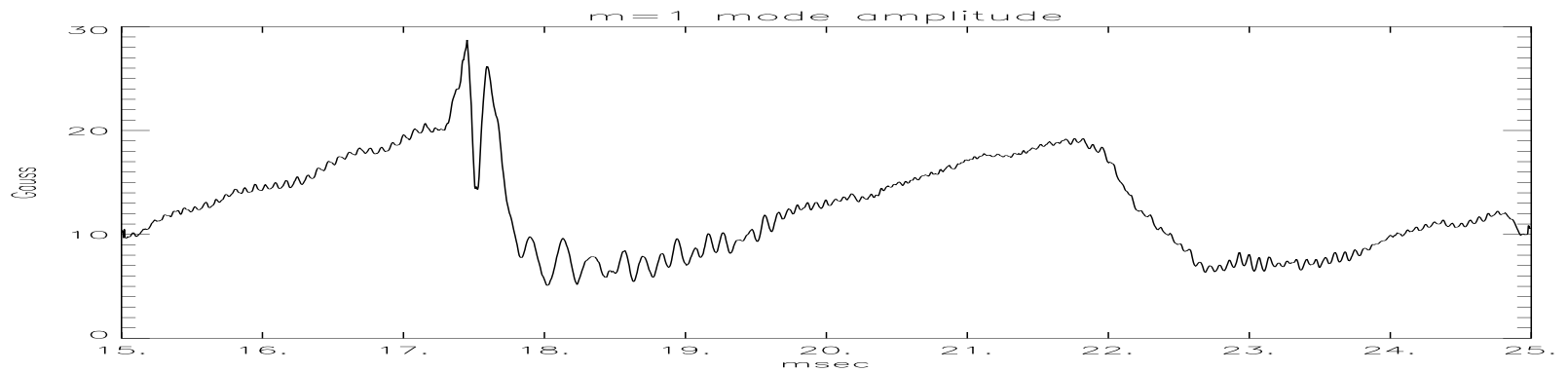

With
Oscillator

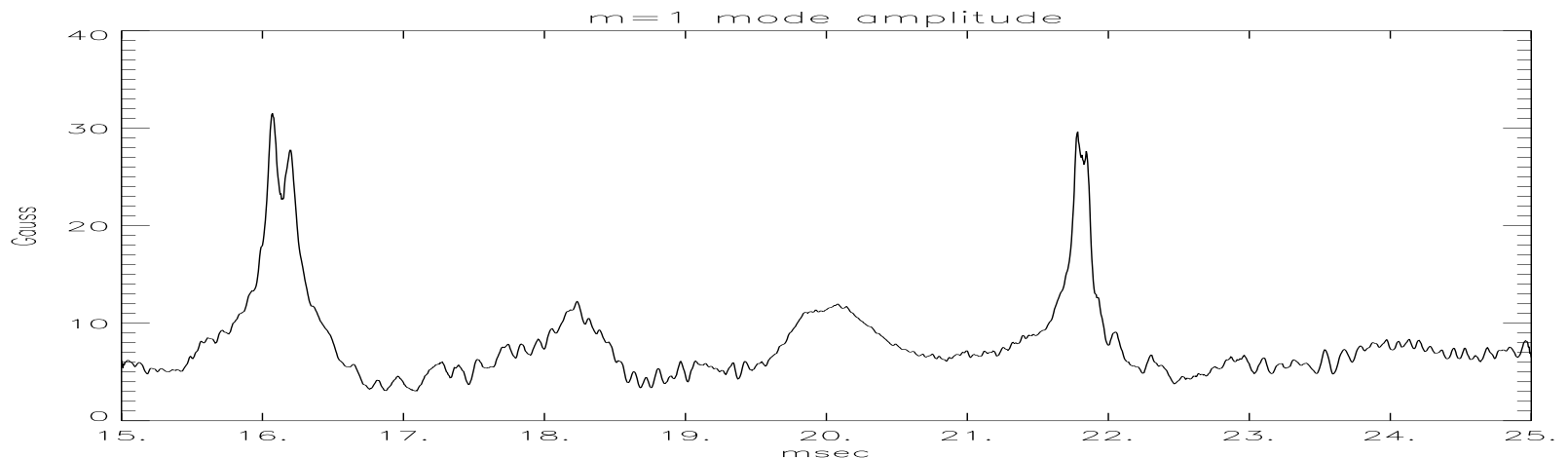

- When oscillator is off we do sometimes see modes grow as fast as when it is on, but the above slow growth never occurs when oscillator is on.
- Flux-injection half of oscillator cycle peaks current profile suddenly forcing a sawtooth event
Why this occurs on only some cycles, whether there is some other driver slowly growing at a rate unaffected by OPCD, remains unexplained.

TOROIDAL SPECTRUM DURING M=0 BUBBLE

Bt n spectrum

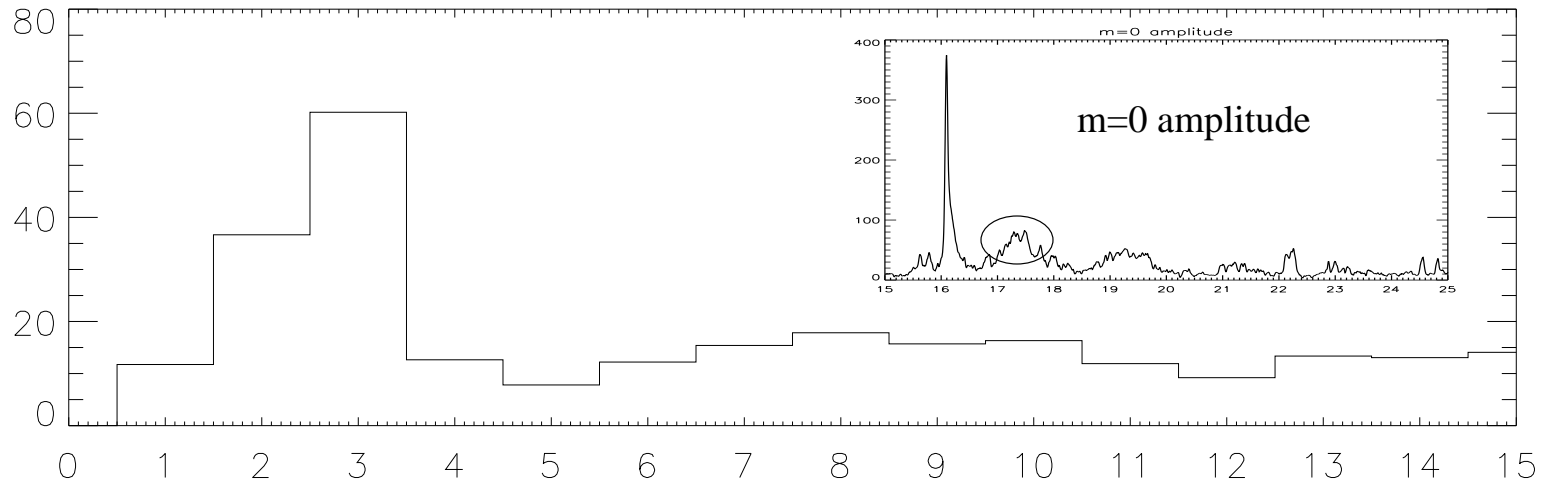

Bp n spectrum

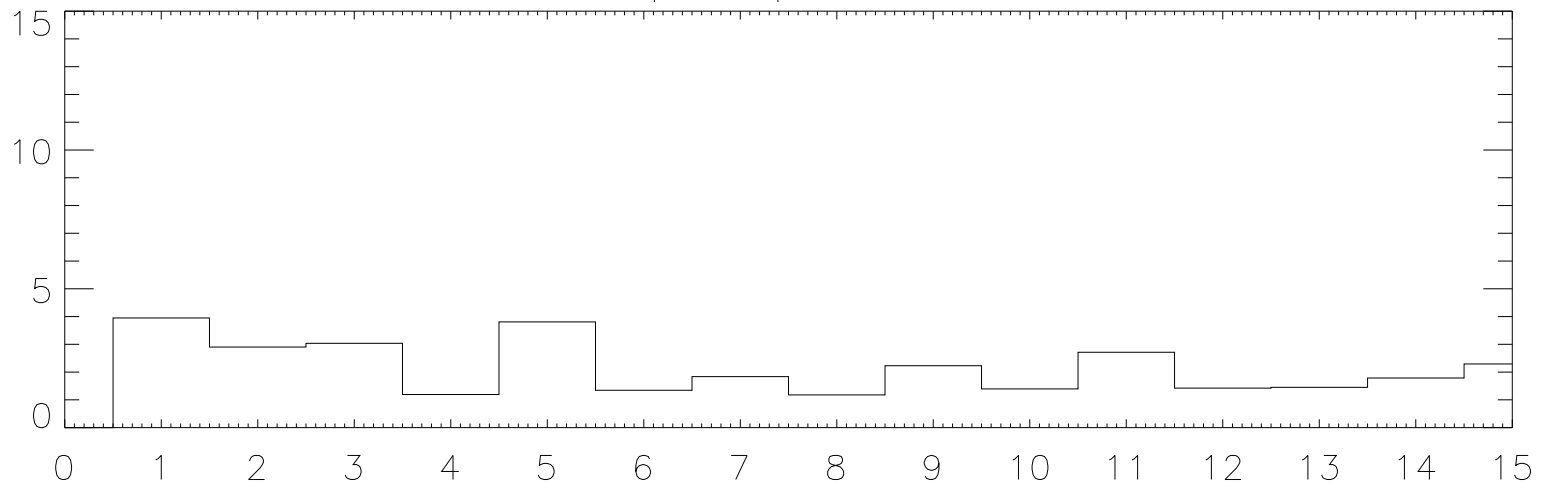

- Dominated by n=3 mode in Bt spectra

TOROIDAL SPECTRUM DURING M=1 BUBBLE

Bt n spectrum

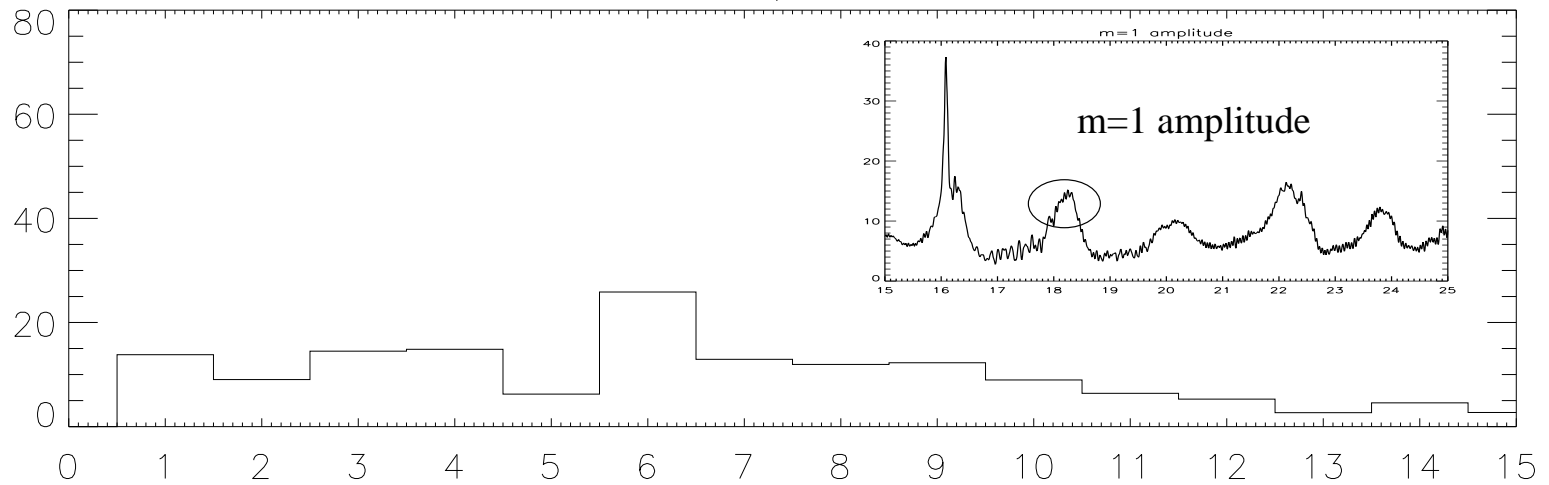

Bp n spectrum

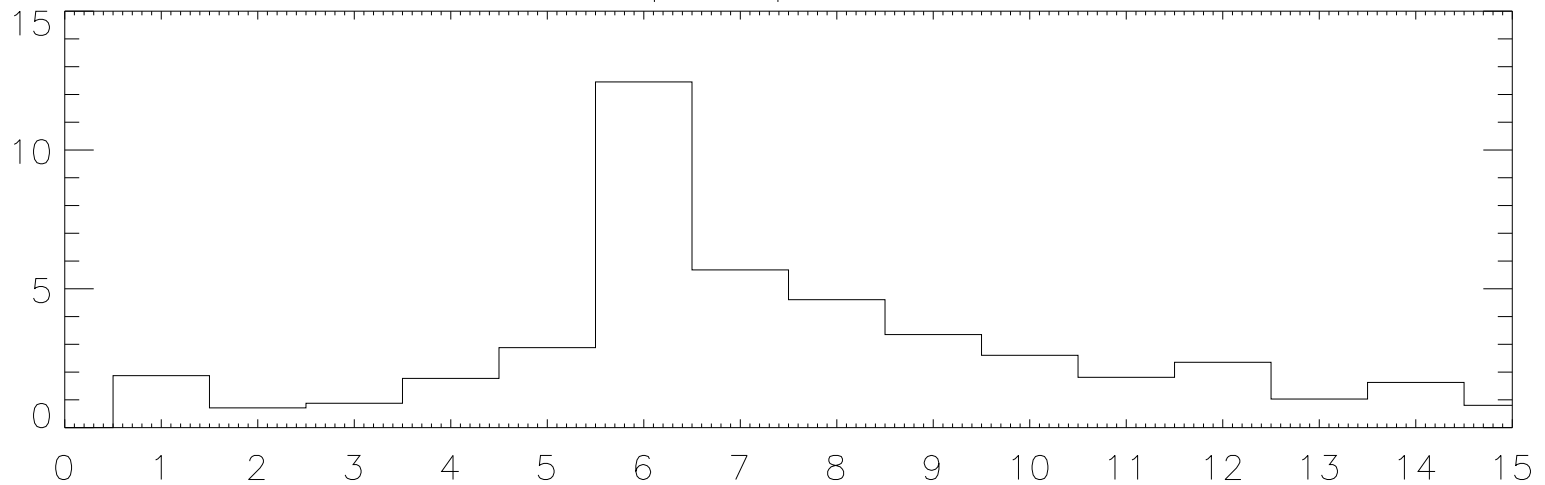

- Dominated by n=6 mode in Bp spectra

TOROIDAL SPECTRUM DURING SAWTOOTH EVENT WITHOUT APPLIED OSCILLATION

Bt n spectrum

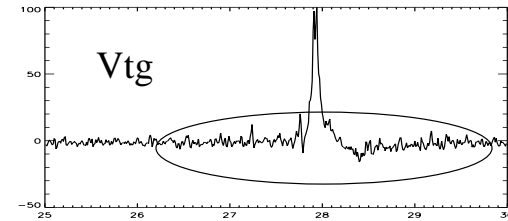
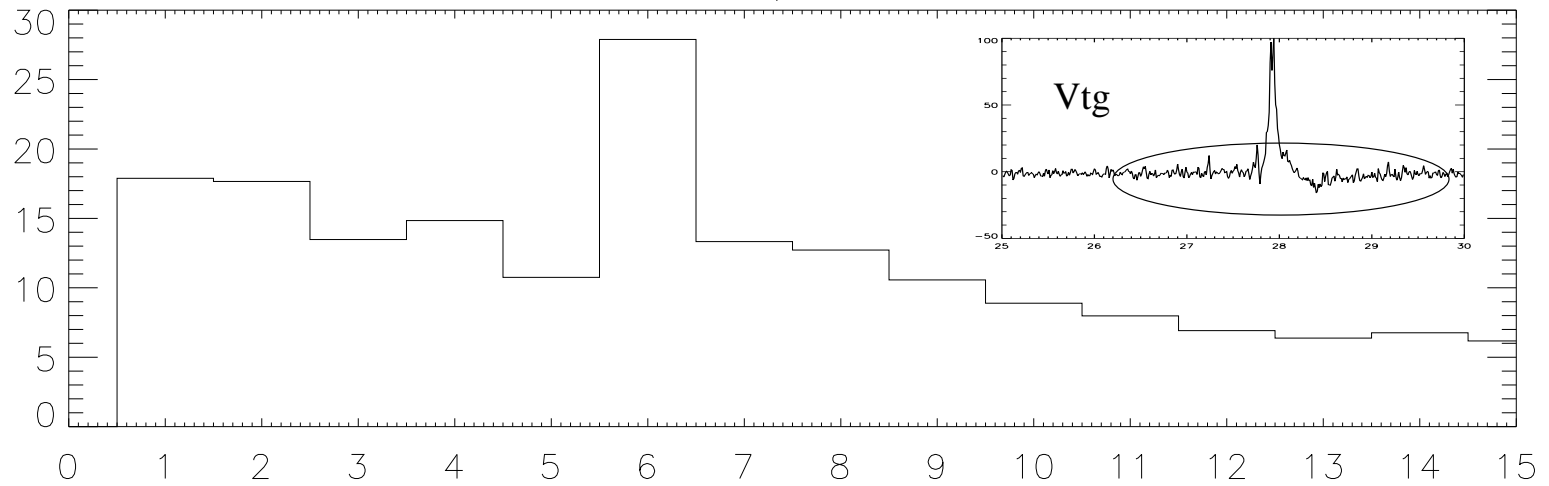

Bp n spectrum

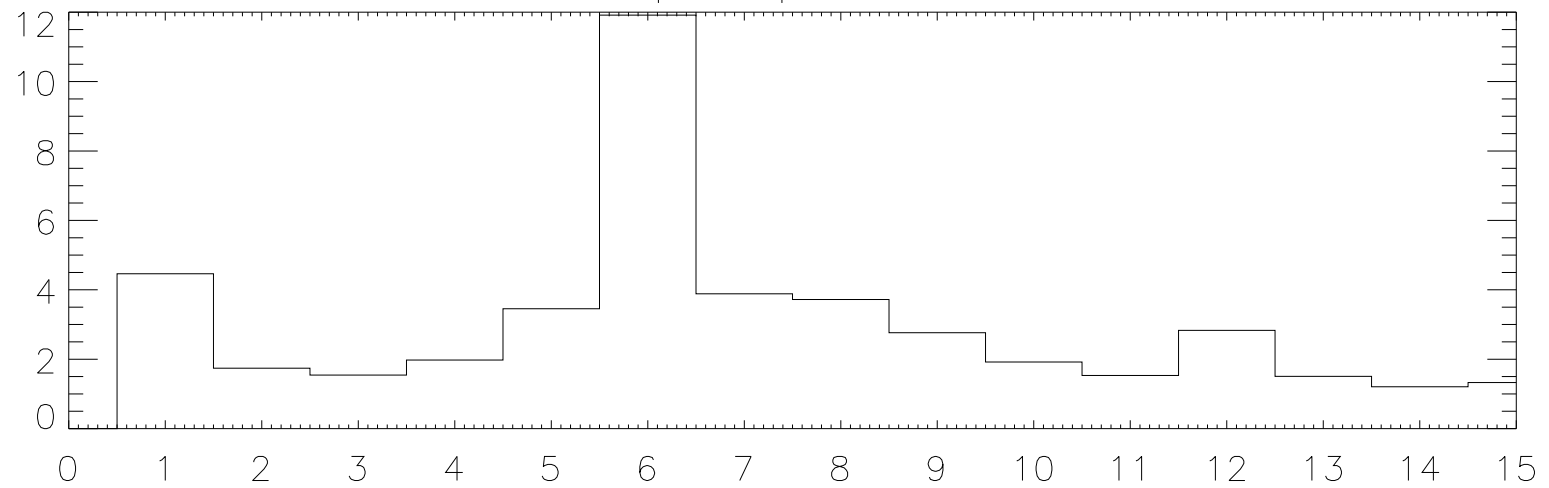

ION TEMPERATURE OSCILLATION

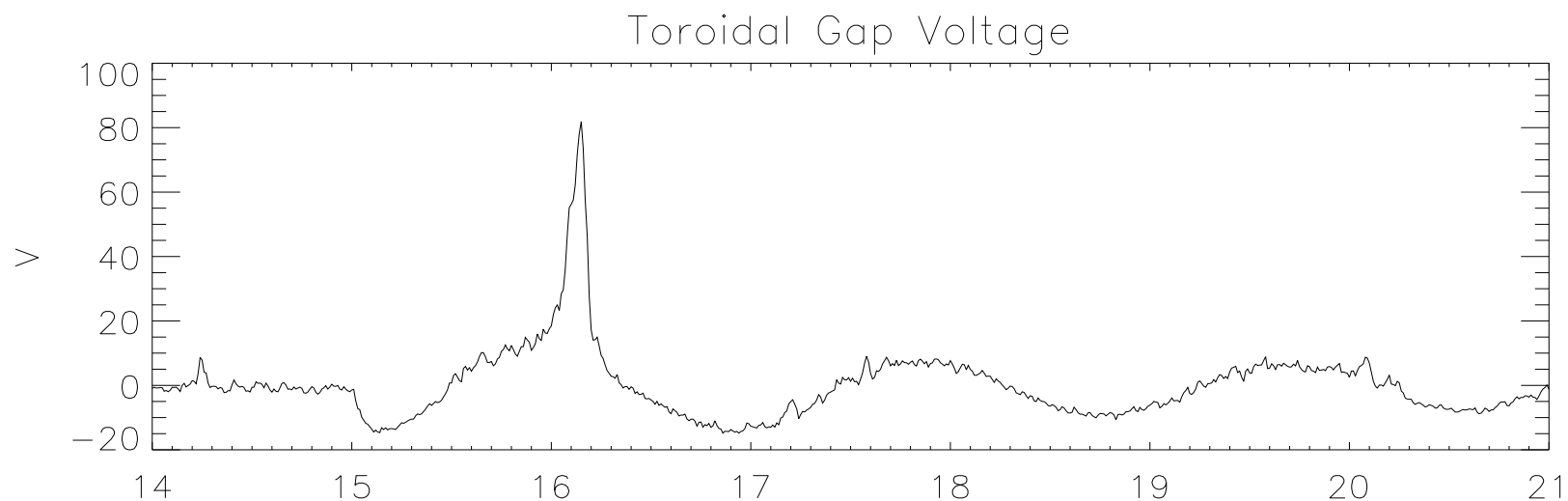
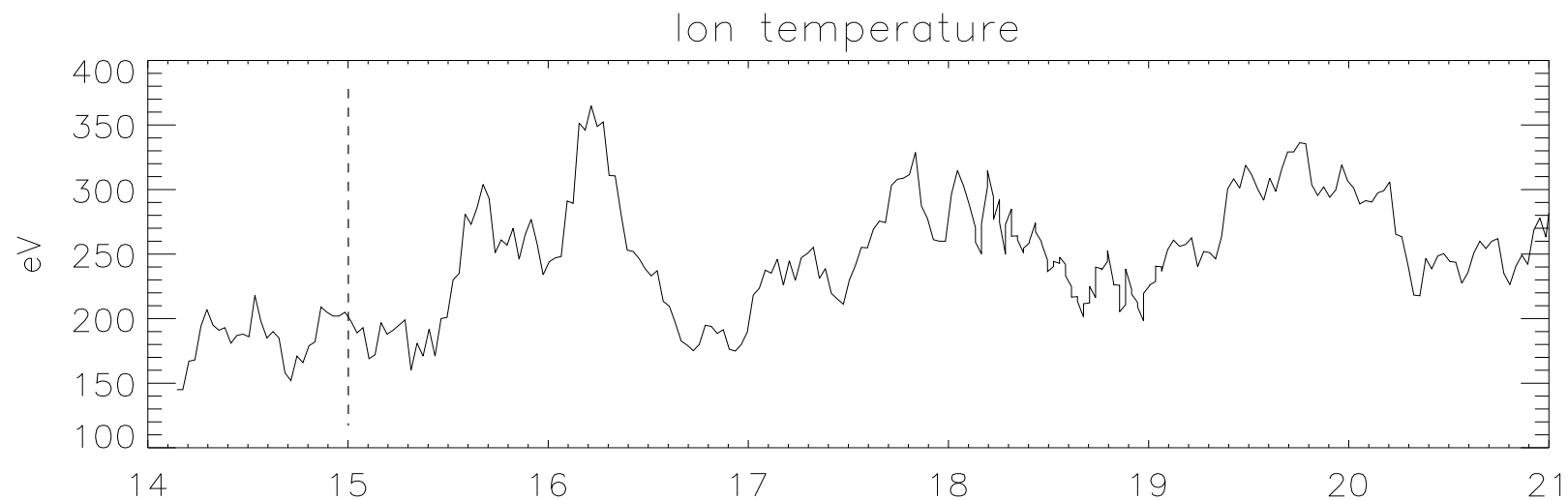

- Ion temperature measured at $r=16.5\text{cm}$. $I_p=380\text{ kA}$. $n=10^{13}\text{cc}$ with Rutherford scattering
- Ion temperature clearly oscillates with applied voltage and appears to be ramping upward.

ELECTRON & ION TEMPERATURE

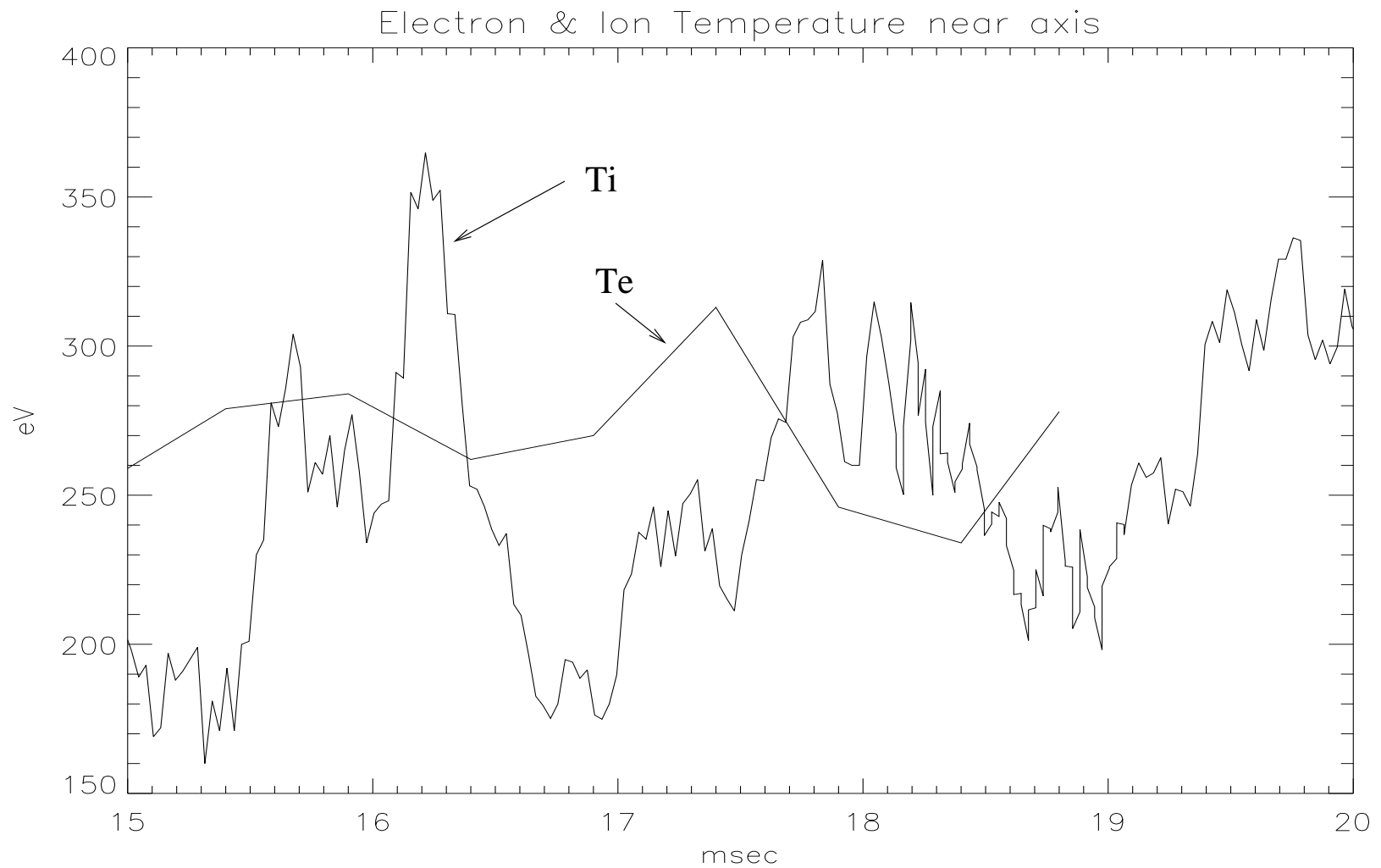

- Ion temperature measured at $r=16.5\text{cm}$. Electron temperature at 6cm
- Slow as the oscillation is, it's not slow enough for T_e to equilibrate with T_i .

Ion Temperature and Magnetic Energy

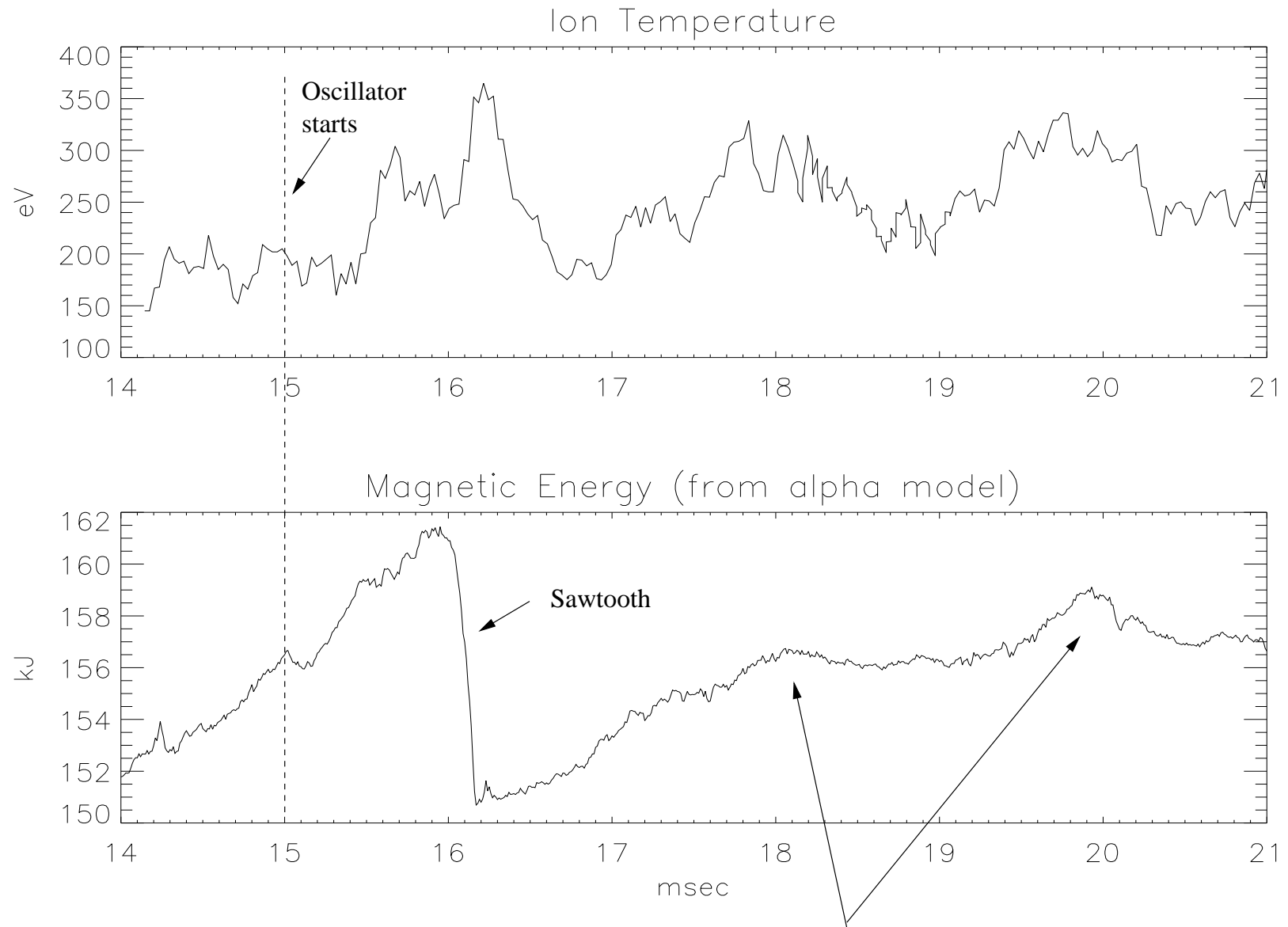

- There may be a small oscillation in magnetic energy.

ION TEMPERATURE OSCILLATION AND MODE AMPLITUDES

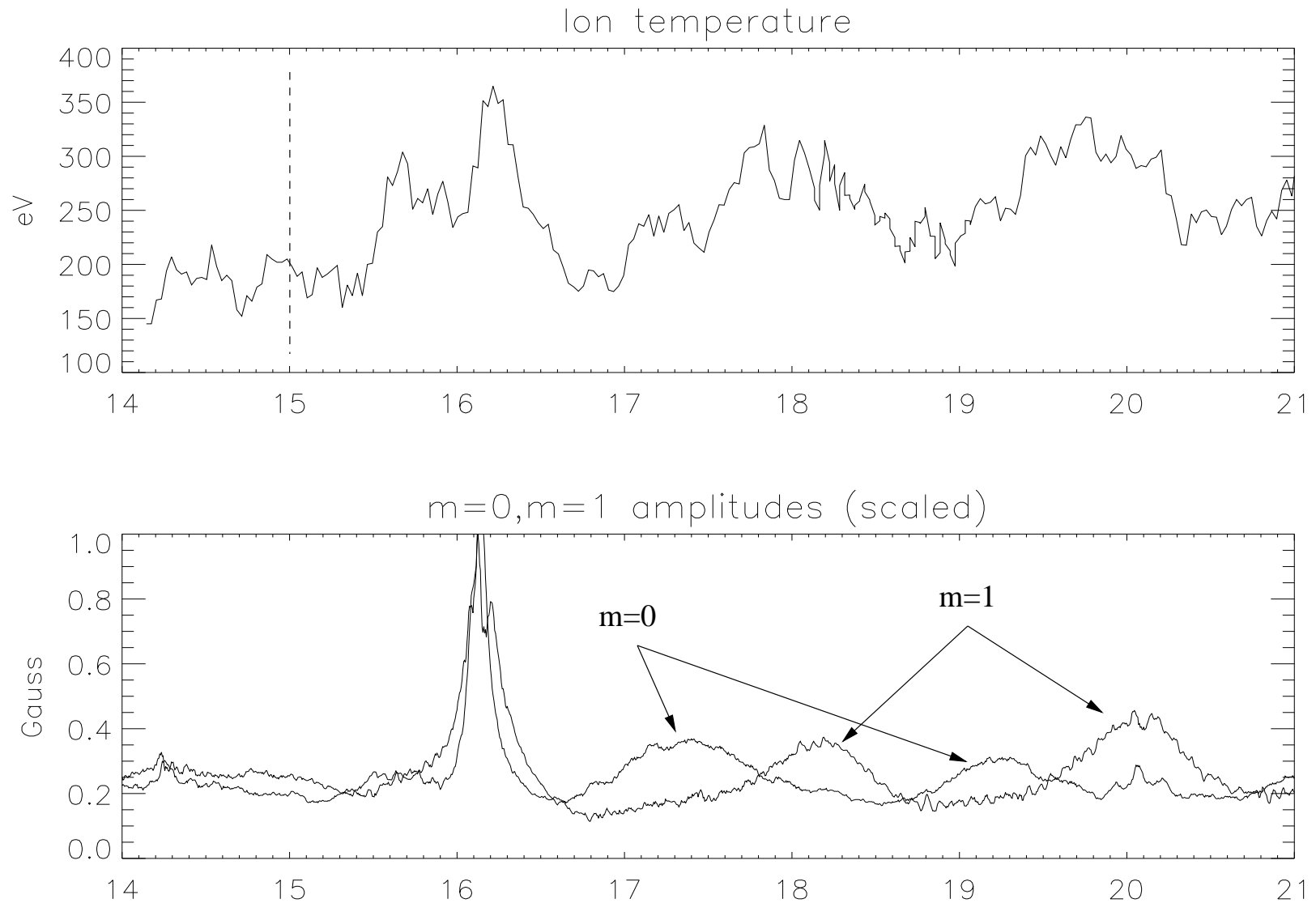

- Ion temperature appears to straddle the timing between m=0 & m=1 excitations.
- Temperature rise may be due to anomalous ion heating.

ION TEMPERATURE AND DENSITY

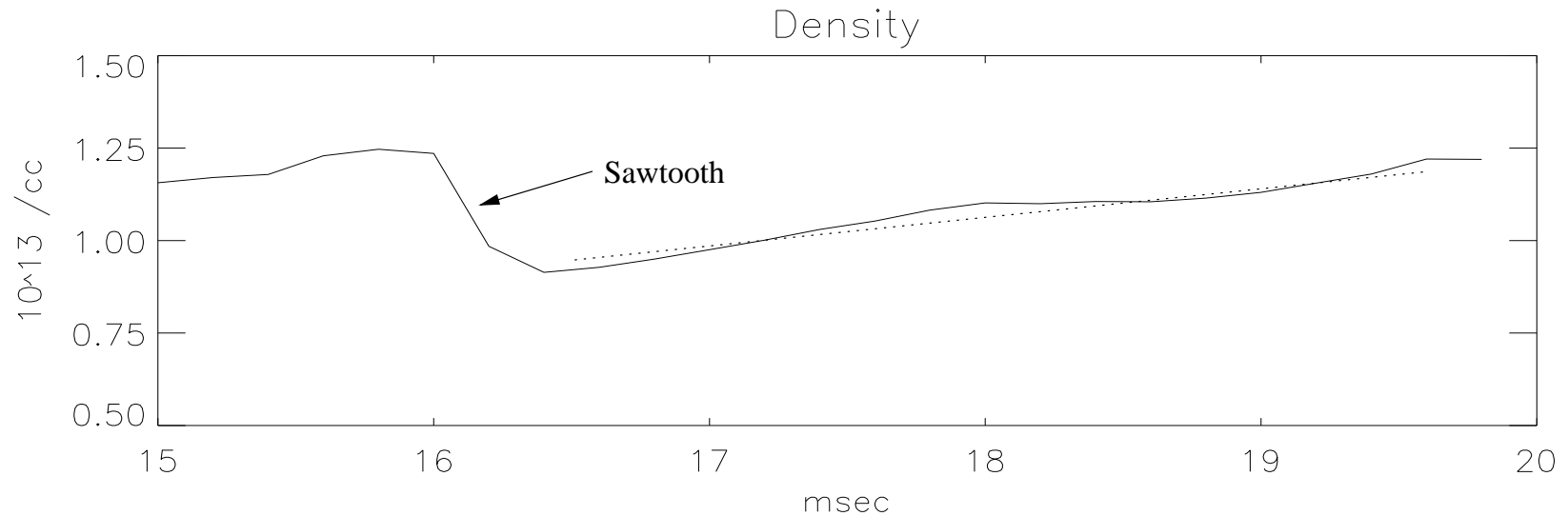
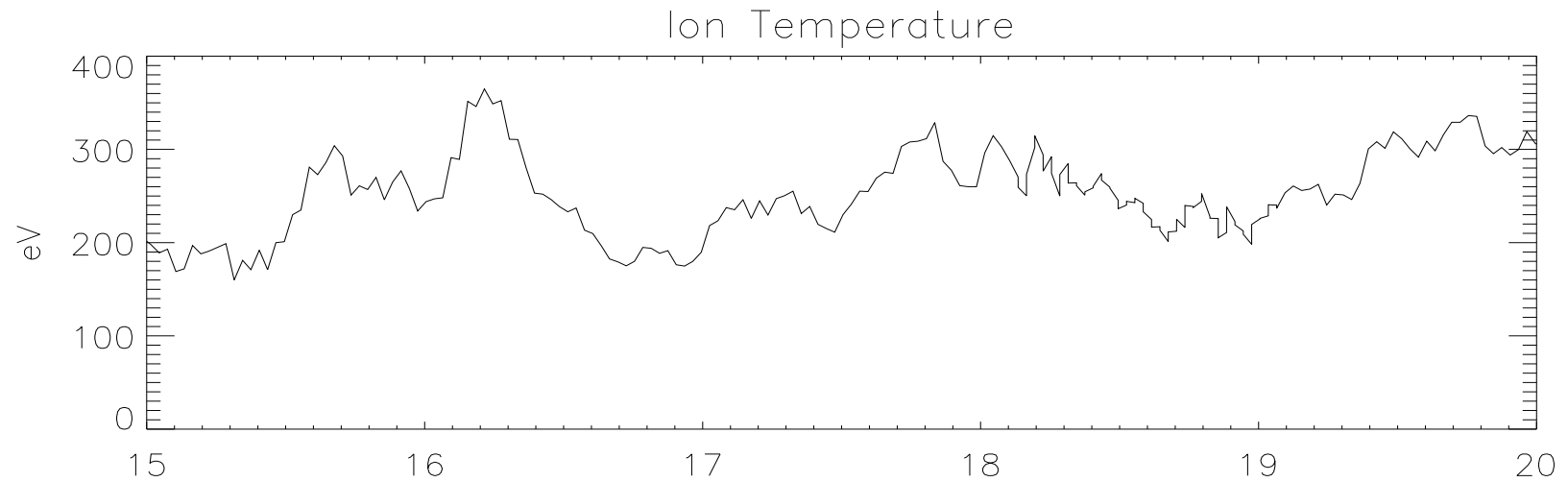

- Density measured with FIR interferometer
- Density maybe displays a slight oscillation

ION TEMPERATURE AND SOFT X-RAY EMISSIONS

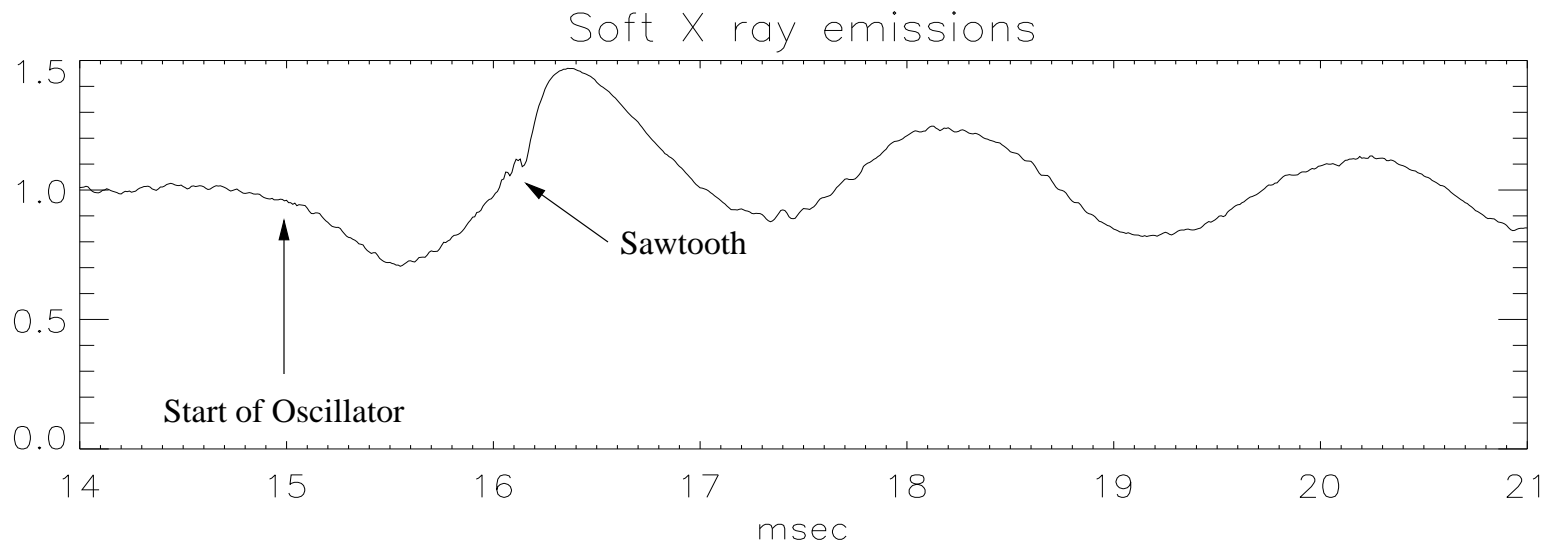
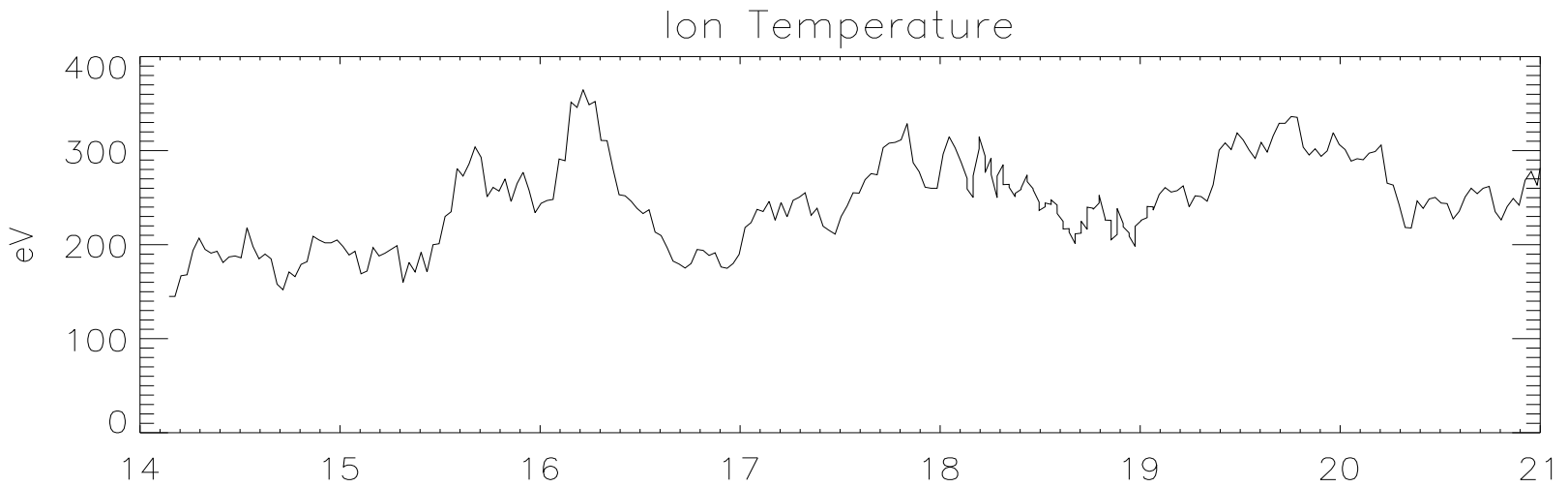

- Soft X-ray clearly shows oscillation.

ENERGY CONFINEMENT DURING OSCILLATION

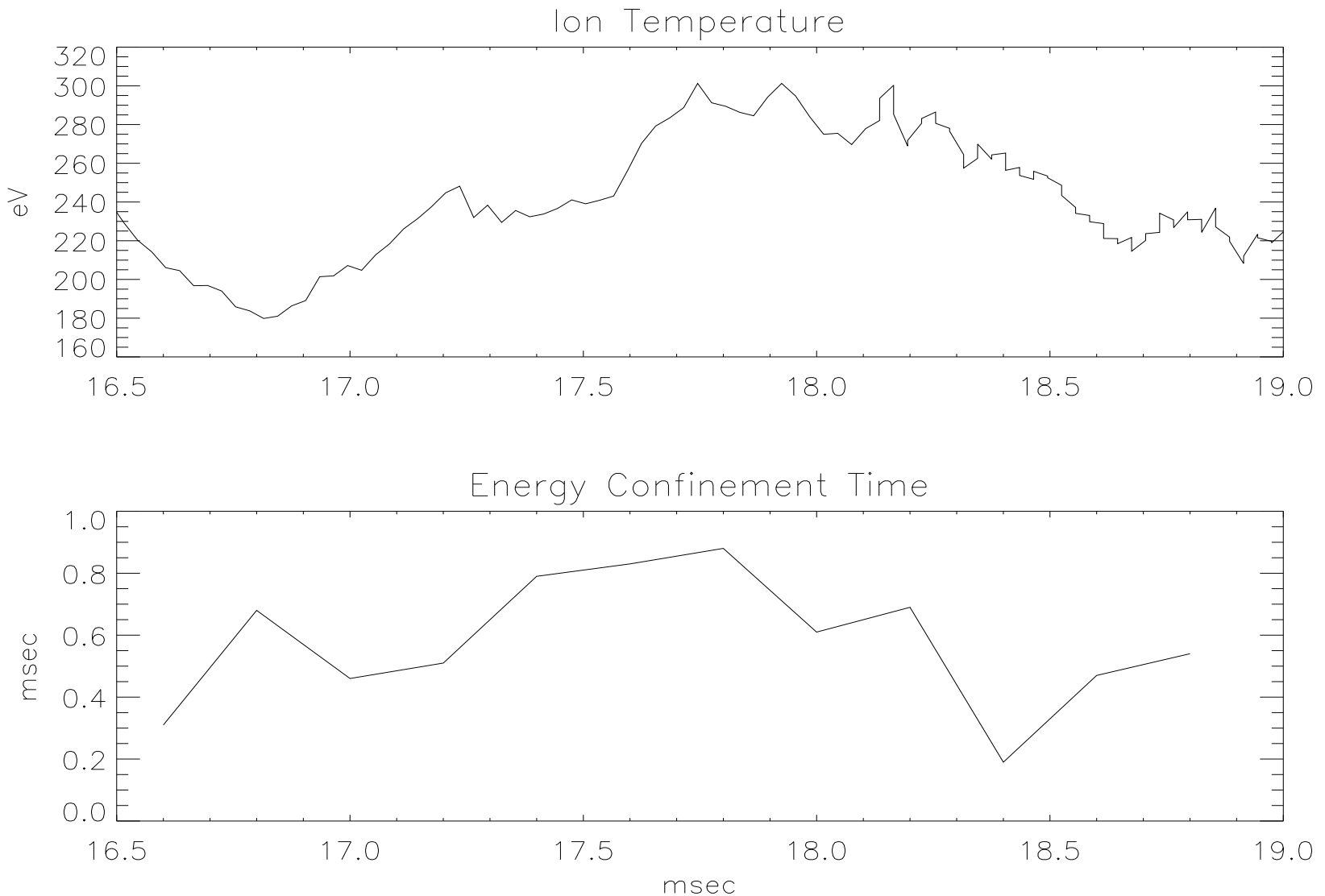

- Confinement time calculated with 'mstfit', see J.K. Anderson poster
— Single shot. Possible correlation. Further study required.

PRELIMINARY RESULTS FOR CURRENT DRIVE

- First limited test of OFCD in MST.
 - Oscillators run only 5 msec and decay rapidly.
 - Plasma impurities were high.

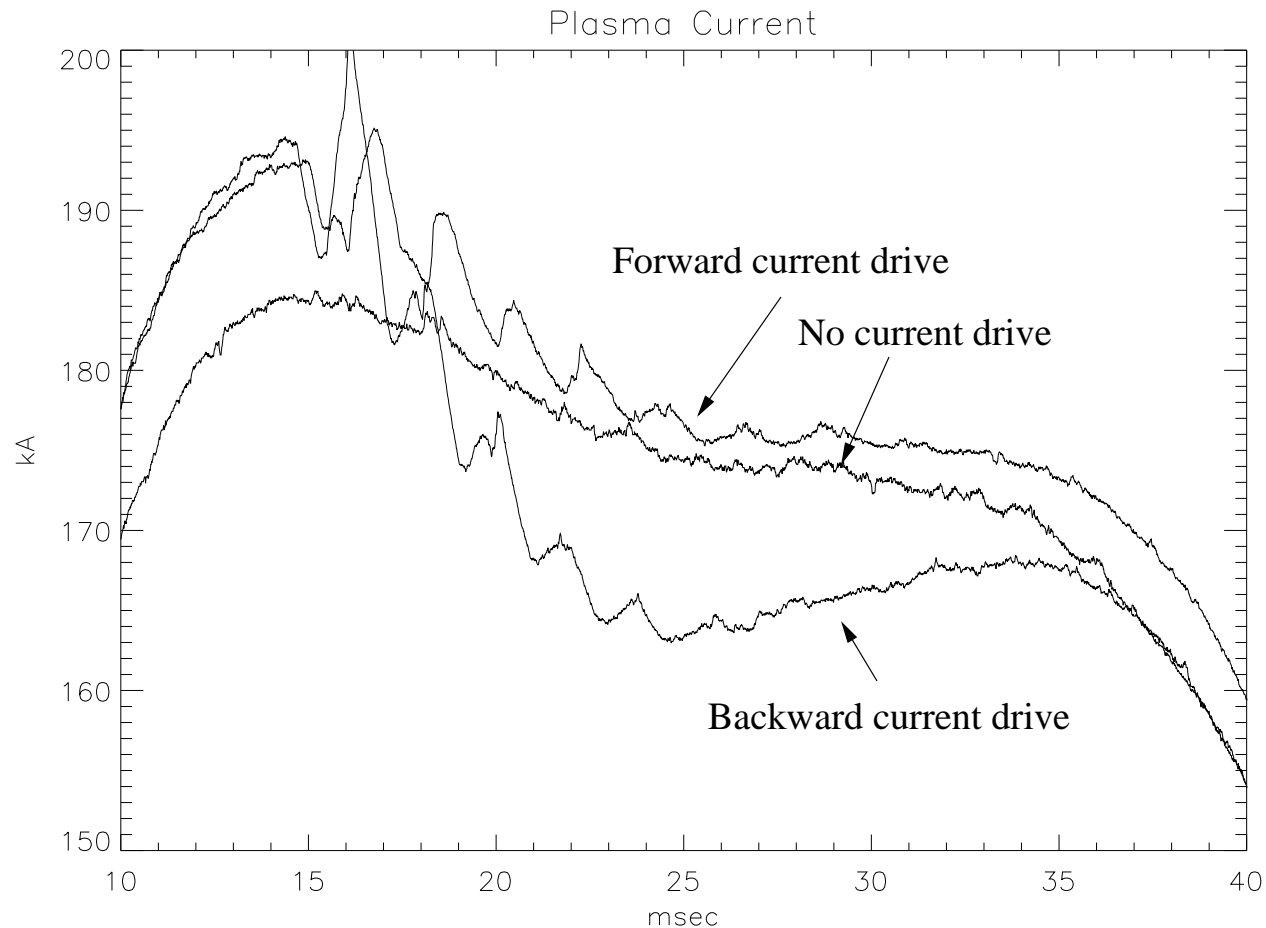

Plans

- Continue studies with both oscillators in place
 - Find optimal conditions for current drive.
- Further study anomalous ion heating during OPCD.
- Replace Ignitrons with Tubes
 - Tubes have faster, more reliable switching performance
 - Tubes used are Machlett model ML8786 tetrodes. 12 MW each
 - Tubes are implemented in a Class–C configuration
 - Looks much like the ignitron based approach
 - Tubes are more expensive than ignitrons (\$80k vs \$10k) but we had them on hand.
 - SPICE Simulations look promising.
 - Good short term high power solution.
- Replace Ignitrons with Solid State Switches
 - Promises performance comparable to tubes
 - Switches are Powerex Gate Commutated Thyristors
 - Oscillator design is for 8 MW.
 - More expensive than ignitrons but less than tubes. \$30k.
 - SPICE Simulations look promising.
 - Probably best long term high power solution

Summary

- Built and tested two oscillators required for OFCD
 - Current studies focus on effect of toroidal circuit oscillator
 - Close to 1 MW peak power
- Observed significant perturbation on toroidal field
 - Some power is absorbed by plasma (~30 kW)
- Observed sawtooth entrainment effect
 - Sawteeth occur on flux injection half of almost every other oscillator cycle, when current profile is peaked.
 - Effect is consistent. Offers a means of controlling timing of tearing modes for further study.
- Ion temperature oscillates in phase with applied voltage.
 - Mechanism of ion heating remains unexplained
- Observed periodic growth in core modes in sync with applied oscillation. Growth in edge modes appears to be 180 degrees out of phase.
- Lack of $m=0$ response between sawteeth suggests $m=0$ mode at sawtooth is linearly unstable rather than nonlinearly driven.
- Energy confinement may be correlated to oscillation
 - Further study is needed
- Preliminary OFCD results indicates current profile is being affected.